

Incorporated (A1043946S)

Competition Rules & Vessel Specifications

DOI	Revision	Author	Checked By	Revisions / Notes
09/02/23	1.0	BC	TR, JW	First Issue for MJWA AGM – To be voted on and adopted
16/02/23	1.1	BC	TR,JW,PW	Amendments applied post AGM - Adoption at GM required
04/04/23	1.1	BC	Committee	Current Rule Set Adopted
02/05/23	1.2	BC	BC/KE	Emergency Additions Avon Specific / Wording Amendments
16/05/23	1.3	BC	BC/JW/TR	Addition of reference drawings

INDEX

THE COMPETITION RULES			
Section	Description	Section	Description
100	General	2200	Protests
200	Definitions	2300	Penalties
300	Competitors	2400	Penalties for Serious Breach
400	Support Crew	2500	Performance Breach
500	Identification Numbers	2600	Penalty for Performance Breach
600	Events	2700	Other Breaches
700	Officials	2800	Penalty for other Breaches
800	Classes	2900	Power to Impose a Penalty
900	Start Finish Marshall	3000	Application of Penalty
1000	Scrutineering	3100	Notification
1100	Pre Event	3200	Unpaid Fines
1200	Post Event	3300	MJWA Championship
1300	Production of Technical Specifications	3400	Race Points
1400	Flags, Timing and Buoys	3500	Event Trophies
1500	Timing	3600	Commodore's Trophy
1600	GPS Tracking	3700	Swimming Tests
1700	Location and Acknowledgement of Flags	3800	Competition Licence
1800	Intoxicants	3900	General Licence
1900	Environment	4000	Insurance
2000	Illegal Assistance	4100	Amendment to the Competition Rules
2100	Withdrawals		
VESSEL SPECIFICATIONS			
Section	Description	Section	Description
5000	Registration	5600	Same Craft to be Used
5100	Identification - Novice Class	5700	Additional Equipment
5200	Identification - Expert Class	5800	Propulsion Systems
5300	Dimensions	5900	Engines
5400	Design and Safety	6000	Mini Jet Classes
5500	Tow Point	6100	Avon Descent Specific Requirements

100. GENERAL

- 101 Mini Jet WA Inc. (hereinafter referred to as the Club) has complied these rules to be known as the Competition Rules of the MJWA (hereinafter referred to as “these Rules”).
- 102 These Rules shall govern all MJWA Competitions.
- 103 The Vessel Specifications are considered to be part of the Competition Rules.
- 104 These Rules shall come into force on 01April 2023 and supersede all previous issues.
- 105 The Secretary shall have a copy of these Rules at all meetings and events of the MJWA.

200. DEFINITIONS

201 ALLOY CLASS

A class of Mini Jet Racing in which the boat is constructed of aluminum alloy (from tow point to transom) and in which the cost of participation is intended to be kept to a minimum in an effort to encourage class numbers to grow.

202 APPROVED

Shall mean approved by a properly constituted General Meeting and published in the Club Newsletter.

203 BEACH LANDING

A landing shall be defined as a beach landing if the as a result of that landing more than 50% of the craft is clear of the water’s edge.

204 Spare

205 BOATAKHANA

An event including only heats designed to test the acceleration and maneuverability of the craft, and the skill and judgement of the driver and co-driver.

206 CIRCUIT RACE

A race on a course involving any corners or departures from a straight path.

207 NAVIGATOR

The person other than the driver carried in a Mini Jet.

208 MINIJET

A marine jet propelled craft that meets all the Specifications 5000 onwards

209 DRIVER

The person in control of the steering of the craft during an event.

210 EVENT

A competition or race in which a Mini Jet takes part and which is given a competitive nature by the publication of results. An event may consist of a series of heats e.g. Circuit events.

211 NWR

Navigable Waters Regulations.

212 INBOARD MOTOR

All parts including the power head, shafts, casings, mounts, covers, as supplied by the manufacturer. Parts carried in the boat during an event are considered part of the Motor for this definition.

213 **SUPPLEMENTARY REGULATIONS**

Regulations supplementary to these rules are compiled by the organiser with the object of explaining the details of an event.

214 **TEAM**

The driver, the co-driver, the craft and the support crew. A team may include more than one entry.

300. COMPETITORS

301 **MINIMUM NUMBER OF COMPETITORS**

The minimum number of competitors in each craft in an event is two.

302 The same competitor(s) shall be in the craft throughout the event.

303 **MINIMUM AGE**

304 The minimum age of a competitor in the solo class is eighteen years.

TYPE OF COMPETITION	AGE OF < 14 Years	Competitor 14 to 16 on or before the 31st Dec of the calendar year of event.	Turning 17 on or before the 31st Dec of the calendar year of event	Minimum grade of License
Avon Descent	No	No	Yes with driver 17+	General
Blackwood Classic	No	No	Yes with driver 17+	General
All other river races and practice/ training days	No	Yes with 17+	Yes	General and Novice
Estuary events (Swan Marathon or Mandurah race or similar	No	Yes if driver is general license holder	Yes	General and Novice

305 **JUNIOR COMPETITOR TO BE ACCOMPANIED**

A junior competitor shall be accompanied by a competitor over the age of seventeen years unless the event is under constant visual supervision by the Race Official in which case two junior competitors may compete together.

306 **AGE AS AT THE DATE OF THE EVENT**

Unless stated otherwise, the age of a competitor is their age as at the date of the event.

307 **INDEMNITY**

A competitor under the age of eighteen years shall have an indemnity form signed by their parent or guardian. This shall be produced to the entry receiving officer before the start of the event.

308 **HOLD A COMPETITION LICENSE**

Each competitor shall be the holder of a current Club competition licence.

309 EXCHANGING ROLES

Competitors may exchange roles as Driver and Co-Driver during an event provided they hold the required grade competition licence.

310 REQUIREMENTS TO WEAR

When a competitor is in a craft on the water they shall always correctly wear the following items that meet the requirements of the MJWA Specifications:

- a) an approved lifejacket (Personal flotation device) PFD
- b) an approved helmet
- c) an approved wetsuit
- d) approved wetsuits are optional at circuit events
- e) footwear.

400 SUPPORT CREW

401 If specified in the Supplementary Regulations each craft shall in an event have a support crew of at least one adult person.

402 The support crew of a team need not necessarily be members of the Club.

403 If specified in the Supplementary Regulations the support crew vehicle shall display the number of the craft it is supporting.

404 Motorbikes shall not be used as support crew vehicles.

405 Each member of the support crew shall make themselves acquainted with these rules and with the Supplementary Regulations of an event.

500 IDENTIFICATION NUMBERS

501 Upon becoming a full financial member or junior member of the Club the member requests a vessel Identification Number.

502 Providing that the number is between 001 and 299 and has not been issued to another member the club will upon payment of the fee issue and authorise that Identification Number for use by the member.

503 The club shall keep a record of all Identification Numbers issued showing to whom issued and date of issue.

504 The Identification Number issued to a member is for their exclusive use for all types of racing and shall be retained by them indefinitely provided the annual fee is paid or unless they decide to change it for a vacant number or unless it becomes vacant.

505 The Identification Number issued to a member shall become vacant if the member ceases to maintain their annual membership subscription by 30 January each year.

506 A vacant Identification Number must be offered to the previous holder before being allocated to another member.

507 There shall be only one craft displaying a particular identification number in any event.

508 Identification Numbers do not determine the order of start unless so stated in the Supplementary Regulations.

509 The required colors, dimensions and placement of identification numbers are listed in these Specifications.

600 EVENTS

601 GENERAL

The Management Committee shall be responsible for scheduling all events.

602 **CLASSES**

The number of classes in an event shall be decided by the Management Committee.

603 **NUMBER OF CRAFT IN A HEAT**

604 The maximum number of craft in a heat shall be decided by the Race Director.

605 The Race Director may decide to conduct a heat in more than one group of craft.

606 Craft shall interchange between these groups according to performance with the last two craft in Group 1 being relegated to Group two and the first two craft from Group two being promoted to group one.

607 **ENTRY**

608 Entry in an event is restricted to holders of valid competition license.

609 The organiser has the right to accept or reject any entry in an event.

610 The entry fee for participation in each event shall be decided by the Management Committee before the first event of the Championships.

611 The entry fee for an event shall be stated in the supplementary regulations.

612 A craft may be entered more than once in an event.

613 An entry in an event presumes that a competitor is aware of the competition rules, the specifications and the supplementary regulations of that event.

614 An entry in an event shall be received by the closing date and time stated in the supplementary regulations.

615 Intending competitors in the Avon Descent have not previously competed in the event shall be required to compete in two Club events.

OR

Participate in ALL three of:

a) a Club Training Day

b) the Official Avon Descent Time Trial Event. (Two Sundays prior to the Event weekend)

c) one of the Official Avon Descent practice sessions on either Saturday afternoon or Sunday morning.

OR

Compete in one Club event

AND

Participate in any two of these three events:

d) a Club Training Day

e) the Official Avon Descent Time Trial Event. (Two Sundays prior to the Event weekend)

f) one of the Official Avon Descent practice sessions on either Saturday afternoon or Sunday morning.

616 Members intending to compete in the Blackwood Classic and who have not previously competed in the event shall be required to compete in one Club river race.

617 a) A competitor who is considered by the Management Committee to be of sufficient proficiency may be allowed entry to the Avon Descent.

a) The Management Committee reserves the right to refuse entry in the Blackwood Classic 250 to a crew they determine to be not of sufficient proficiency to safely enter the event

700 **OFFICIALS**

Each event shall have the following officials:

- Race Director
- Judge/Timekeeper/Lap Counter/GPS Monitor
- Scrutineer
- Starter/Finish Marshall

701 **PLURALITY OF DUTIES**
If so decided by the organiser a person may fulfil the role of more than one of the above listed tasks.

702 **RESCUE / RECOVERY**
A rescue/recovery craft shall be available at each event.

703 The rescue craft shall fly a green and white flag.

704 **PIT AREA**

705 Each event shall have a pit area that shall be clearly defined in the Supplementary Regulations.

706 Pit Area Rules

- No Smoking in Pit area.
- No Alcohol consumption in pit area.
- A power tool area will be located separate to the pit area for all repairs requiring power tools.
- Timed repairs to a motor are restricted to the pit area or allocated repair area Only.
- Any tools may be used in the repair. Cordless tools are allowed.
- Two (2) people only are allowed to use the tools to repair.
- One (1) person using the tools has to be from the crew that race that craft.
- One (1) person is allowed to pass parts or tools but shall not do any of the repairs.
- All work to motors will be timed and filmed in area designated for the work with an exclusion zone organised by Race Director or Scrutineer for public viewing.
- The total time elapsed in the replacement or repair of a part or parts shall be recorded. There shall be no stopping of the timing (however, see below). Multiple repairs may be able to be stopped depending on the repair and at the discretion of the Race Director or Scrutineer.
- Repairs that require a part to be taken away from the Pit Area shall attract a penalty of five minutes in addition to the time recorded to remove and refit the part.
- Timed repairs will be done at a time and place allocated by the Race Director or Scrutineer.

707 Consumption of intoxicants is not allowed (see 1800)

708 The details of the right to enter and remain in a pit area shall be stated in the Supplementary Regulations of an event.

800 **CLASSES**

801 There shall be TWO (2) classes of competition:

MINIJET NOVICE

Craft conforming to all the specifications of these Specifications and comply with section 3901.

MINIJET EXPERT

Craft conforming to all the specifications of these Specifications and comply with section 3902.

802

Provided there is a minimum of three craft on the water to contest a heat or event, the minimum number of craft to constitute a class for points is 2. The Race Director has the final say in the eligibility of the additional craft, if required, that will enter to comprise the third entry.

The additional craft will not be eligible for points, plaques or prizes for that event.

OFFICIALS

RACE DIRECTOR

The organiser shall appoint a Management Committee approved Race Director for an event.

The Race Director shall be responsible for the conduct of the event.

The Race Director shall report all protests to the Management Committee as soon as practicable.

SCRUTINEER

The Scrutineer shall have the ultimate responsibility for the scrutineering of each event.

900 STARTER / FINISH MARSHALL

901 The organiser shall appoint a starter / finish marshal for an event.

902 The starter / finish marshal shall have assistant marshals as required.

903 The starter shall the event.

904 The finish marshal shall be present at the finish of an event or nominate an assistant marshal to be present to record the completion of each competing craft.

905 JUDGE

906 The organiser shall appoint a judge for an event, if required.

907 The judge may have assistant judges as required.

908 The judge and assistant judges shall decide whether a craft has touched a buoy or passed a line or some other fact as described in the supplementary regulations.

909 The decision of a judge or assistant judge maybe altered only by protest or appeal.

910 TIMEKEEPER

911 The organiser shall appoint a timekeeper for an event.

912 The timekeeper shall be responsible for all aspects of timing an event.

913 The timekeeper may have assistant timekeepers as required.

914 PLURALITY OF DUTIES

The organiser may decide that the same person may undertake several of the listed duties (see also 634).

915 NO ALCOHOL

Members designated as an official at any Club event must not consume alcohol while any craft is on the water and officials are performing their duties.

1000 SCRUTINEERING

1010 Scrutineering requirements have been designed for the following reasons:

a) To provide safety for all competitors

b) To provide a standard to facilitate scrutineering

c) To comply with the Government Department requirements as stated in the NWR.

d) To aid officials at an event.

e) To allow all competitors to compete on an equal basis with other craft in their class.

1100 PRE EVENT SCRUTINEERING

1101 Each craft entered in an event shall be presented at pre event scrutineering in start line condition.

1102 Any modification, substitution, addition or deletion from such condition shall be passed by the event scrutineer / event scrutineer before the start of an event.

1103 At pre event scrutineering each craft shall meet the requirements of the Specifications as applicable to the class in which it is entered.

1104 A craft shall meet the scrutineering requirements on each day of an event.

1105 A craft that fails to meet the scrutineering requirements before the start of each day of an event shall be withdrawn from the event by the Scrutineer until all scrutineering requirements have been met.

1200 POST EVENT SCRUTINEERING

1201 Post event scrutineering shall be conducted after a review of collated GPS data and the application of time penalties as outlined by the Supplementary Regulations for the event.

1300 PRODUCTION OF TECHNICAL SPECIFICATIONS

If the full technical specifications for a motor or craft are not listed in this manual it is the responsibility of the competitor racing that motor or craft to provide the complete list of measurements required (as a list in the technical specifications section of this manual) fourteen days prior to pre event scrutineering or make alternative arrangements with the Rules Committee 14 days prior to the commencement of the event.

1400 START, FINISH, TIMING, FLAGS AND BUOYS

1401 Start / Finish

1402 The method of starting shall be as stated in the Supplementary Regulations for an event and if not stated shall be either of:

- a) Flying start on the water
- b) Standing start from land

1403 A craft shall not cross the start line before the start signal.

1405 A craft shall be judged to have crossed a start line or finish line at the moment the bow has passed that line.

1406 The penalty for a false start shall be a 60 second penalty added to the elapsed time of the offending craft or such other penalty as stated in the supplementary regulations.

1407 Re-rounding of buoys or start line shall not prevent the penalty being applied and shall not be permitted.

1408 A circuit race shall be re started if in the opinion of the Race Director the Identification Numbers of the craft cannot be accurately judged.

1409 Supplementary Regulations shall stipulate whether the motor shall be running or stopped before the start.

1410 A circuit race shall be re started if in the opinion of the starter / judge / race director, 50% of the field has broken the start.

1500 TIMING

The timing shall commence on the display of the start signal regardless of the position of a craft at the moment of display.

1600 Minijet GPS Tracking System

The GPS tracking system referred to in Specification 6000 shall be approved annually for the following racing calendar year. That approval shall be made by majority vote at the Club Annual General Meeting.

Loss of data for any event shall be deemed as a non-result in all racing events.

1700 LOCATION AND ACKNOWLEDGEMENT OF FLAGS

A driver shall give a signal of acknowledgement that they have seen a flag or flags displayed at the start / finish position as they pass that point.

1701 BLUE AND WHITE FLAGS

Both flags shall be raised fifteen seconds before the start time. The blue flag shall be dropped five seconds before the start time and the white flag shall be dropped for the start.

1702 CHECKERED FLAG

Finish. In a circuit race it shall be shown stationary or waved to the first craft as it crosses the finish line and then in succession to each other craft as they next cross the finish line after the first craft regardless of the lap they may be on

1703 BLACK FLAG

Excluded from that and any points gained shall not count (Not disqualified from the event). The flag shall be pointed directly at the offending craft which shall be removed from the water safely and directly.

1704 RED FLAG

Clear the course in a circuit race.
Stop in a river race.

1705 YELLOW FLAG

One lap to finish in a circuit race.
Caution in a river race.

- 1706 **ORANGE FLAG WITH WHITE STRIPE**
Caution in a circuit race.
- 1707 **GREEN FLAG**
Sixty seconds to start.
- 1708 **WHITE FLAG WITH BLACK CROSS**
Error (boatakana).
- 1709 **GREEN AND WHITE FLAG**
Rescue Craft.
- 1710 **BUOYS**
Used as required to demarcate the racecourse for the day
- 1800 INTOXICANTS**
- 1801 Competitors shall not consume any intoxicants less than six hours before the start of an event and until they have finished the days racing.
- 1802 Intoxicants shall not be consumed in the pit area during a one day event.
- 1803 The Race Director may cause a competitor to be tested to ensure that their blood alcohol content does not exceed 0.00 and if it does preclude them from entry in or disqualify them from an event.
- 1804 Failure to comply with 1801 and 1802 will result in disqualification from the event.
- 1900 ENVIRONMENT AND LITTERING**
- 1901 The Club aims to protect the environment at all times.
- 1902 A team that deliberately commits any action that has an adverse effect on the environment shall be penalised as provided in section 2300.
- 1903 A team that litters shall be penalised as provided in section 2300.
- 2000 ILLEGAL ASSISTANCE**
- 2001 A competitor shall not accept assistance from the public or a support crew that takes their craft nearer the finish including following in the wake of other non-competing craft.
- 2002 Competitors may assist other competitors if the way is blocked.
- 2003 Competitors may assist other competitors in the case of impending physical danger.
- 2004 Failure to comply with rule 2001 shall result in a penalty in accordance with section 2300.
- 2100 WITHDRAWALS**
- 2101 A team that withdraws from any event must notify an official immediately.
- 2102 Failure to notify withdrawal shall result in a penalty in accordance with section 2300.
- 2200 PROTESTS**
- 2201 RIGHT TO PROTEST**
The right to protest lies solely with any competitor who may consider themselves aggrieved or affected by any decision, act or omission of an official, competitor or any other person connected with an event except that there shall be no right to protest against a judgement of fact.
- 2202 DEFINITION OF A FACT**
A fact for the purpose of rule 2001 above is a requirement of the competition rules, the specifications and / or the supplementary regulations of an event.
- 2203 ACTION OF OFFICIAL**
Nothing in these rules shall affect or prejudice the right and duty of any official to take such action as they may deem proper regardless of whether a protest has been lodged.
- 2204 LODGING A PROTEST – TO WHOM DIRECTED**
A protest shall be in writing, signed by the competitor making the protest, accompanied by the fee of one hundred dollars (\$100.00) or such amount determined from time to time by the Management Committee which will be stated in the supplementary regulations and be directed to the Race Director.
- 2205 WITHDRAWAL OF A PROTEST**

Nothing in these rules shall prevent the withdrawal of a protest before its hearing. The fee shall be returned if the protest is withdrawn.

2206 TIME LIMIT FOR PROTEST

A protest as to the validity of an entry shall be lodged not later than one hour before the start of an event. A protest of this nature shall be required to specify the details of such alleged ineligibility and shall not otherwise be accepted.

2207 A protest against mistake, irregularity or act to the prejudice of an event or other matter occurring or becoming apparent while the event is taking place (including a penalty applied to a team) shall be lodged as soon as possible after the occurrence but in any case, not later than thirty (30) minutes after the finish of the event (see rule 670) and shall not otherwise be allowed.

2208 In the case of a protest arising out of post event scrutineering, the protest shall be lodged within thirty (30) minutes of scrutineering results being announced.

2209 COMPETING UNDER PROTEST

After the lodging of a protest the team aggrieved shall retain their position in the event, including start grid position pending the outcome of the protest.

2210 ADJUDICATION OF PROTEST

2211 A protest relating to the validity of an entry, ineligibility of a craft, non-compliance with the specifications or similar technical matter relating specifically to the boat or motor shall be referred to the Management Committee for hearing.

2212 A protest shall be heard by a Protest Tribunal consisting of:

a) the Race Director, who shall be the chairperson (replacement is a member of the organising committee).

b) two members of the organising committee
(Replacement is a member of the Management Committee).

2213 No person may sit on a protest tribunal who may be or has been directly concerned or involved in the matter under consideration).

2214 HEARING OF PROTESTS

2215 The protest hearing shall take place as soon as practicable after the lodging of the protest.

2216 All parties aggrieved or affected shall be given twenty four (24) hours notice by the chairperson of the time, date and place of the protest hearing unless all parties agree to less notice. They shall be entitled to call witnesses but shall state their case in person.

2217 JUDGEMENT

All parties aggrieved or affected by the decision of a protest tribunal shall be bound by the decision subject only to appeal as provided in these rules.

2218 FORFEITURE OF PROTEST FEE

2219 Unless otherwise decided by the protest tribunal for special reasons the protest fee shall normally be forfeited if the protest is dismissed.

2220 If a protest results in a motor being stripped, and the protest subsequently dismissed, the protest fee shall be awarded to the team whose motor is stripped.

2221 APPEALS

2222 RIGHT TO APPEAL

Persons aggrieved or affected by the decision of a protest tribunal (competitors or officials) have the right to appeal against the decision only.

2223 TIME LIMIT FOR APPEAL

2224 An appeal shall be in writing, signed by the appellant, accompanied by the fee of \$100.00 and delivered to the chairperson of the protest tribunal within one hour of the decision. The chairperson shall advise the secretary of the appeal as soon as practicable.

2225 The details of the appeal shall be lodged with the secretary within seven days of the decision of the protest tribunal.

2226 **COMPETING DURING APPEAL**
After the lodging of an appeal the team aggrieved shall retain their position in the event, including start grid position, pending the outcome of the appeal.

2227 **ADJUDICATION OF APPEAL**

2228 An appeal will be heard by an appeal tribunal selected from the Management Committee.

2229 No person may sit on the appeal tribunal who may have already participated in a decision on the matter in question or who may directly or indirectly be concerned in it.

2230 **HEARING OF AN APPEAL**

2231 The hearing of an appeal shall take place as soon as practicable after the decision of the protest tribunal.

2232 All parties aggrieved or affected shall be given adequate notice by the chairperson of the appeal tribunal of the time, date and place of the appeal hearing. They shall be entitled to call witnesses but shall state their case in person.

2234 It is incumbent on the appellant to obtain details of the protest hearing from the chairperson of the protest tribunal, if required.

JUDGEMENT

2235 The decision of the appeal tribunal shall be final.

2236 **APPEAL FEE**

Unless otherwise decided by the appeal tribunal for special reasons the appeal fee shall normally be forfeited if the appeal is dismissed.

2300

PENALTIES

2301 Serious breaches.

2302 Environmental damage including littering and felling of trees.

2303 Refuelling outside official refuelling areas.

2304 Incorrect refuelling procedures.

2305 Incorrect disposal of waste fuel.

2306 Beach Landings.

2307 Failure to render assistance in an emergency situation.

2308 Consumption of intoxicants six (6) hours before the start of each days racing and / or before leaving the water.

2309 Passing a checkpoint with an injury requiring medical assistance.

2310 Failure to notify withdrawal.

2311 Failure to follow the reasonable request of an official.

2312 Failure to leave the water after having been withdrawn by an authorised official.

2313 Abuse of an official.

2314 Failure to obey an official flag.

2315 Acting in a manner detrimental to other competitors.

2316 Continued and deliberate exceedance of maximum stated class speeds.

2400 PENALTIES FOR SERIOUS BREACHES

2401 Cancellation or suspension of Club competition license.

2402 Time penalty (not set maximum).

2403 Monetary fine (\$250.00 maximum).

2404 Membership expulsion.

2500 PERFORMANCE BREACHES

2501 Incorrect start procedure.

2502 Incorrect portage.

2503 Accepting illegal assistance.

2504 Interference with other competing craft.

2505 Unauthorised repairs to motors.

- 2506 Non-compliance with the technical specifications.
2507 Non-compliance with section 8 of the specifications.
2508 Unintentional exceedance of maximum stated class speed

2600 PENALTIES FOR PERFORMANCE BREACHES

The maximum penalty for these breaches is a time penalty of fifteen (15) minutes except for a breach of rule 2313 and / or 2315 which maybe a time penalty (no maximum) a monetary fine (maximum \$250.00) or both, or disqualification.

2700 OTHER BREACHES

- 2701 Unauthorised practice after the start of an event.
2702 Failure to place a craft in a pit area immediately after finishing each days racing.
2703 Unauthorised entry to the pit area during closed time.
2704 Unauthorised removal of a craft from the pit area.
2705 Smoking in the pit area.
2706 Failure to present a craft in start line condition at pre event scrutineering.
2707 Non-compliance with the specifications on each day of an event.
2708 Unauthorised replacement of competitors.
2709 Non-compliance with the competition rules.

2800 PENALTIES FOR OTHER BREACHES

The penalty for other breaches may range from a warning to a maximum fine of \$100.00, or a time penalty (no set maximum) or any combination of the two.

2900 POWER TO IMPOSE A PENALTY

- 2901 In an event the Race Director shall have the power to impose a penalty.
2902 In other circumstances the Management Committee shall have the power to impose a penalty.

3000 APPLICATION OF A PENALTY

In the consideration of the application of a penalty towards a team for a breach of these Rules it shall not be considered an excuse, defence or mitigation factor that the member of the team was unaware of the existence of the rule.

3100 NOTIFICATION

- 3101 The imposition of a penalty may be advised verbally. This verbal notification shall be confirmed by written notification from the Race Director or Management Committee stating the alleged breach and quoting the specific competition rule that is alleged to have been breached and the penalty applied and quoting the specific competition rule giving authority for the application of the penalty as soon as possible after the verbal notification is given.

3200 UNPAID FINES

Should a fine be imposed for a breach of these rules and that fine is not paid before a subsequent event, entry into that event shall be refused by the organiser until the fine is paid.

3300 MINI JET WA CHAMPIONSHIPS AND PERPETUAL TROPHIES

- 3501 The Mini Jet WA Championships are open to all financial members of the Club.
3502 The Club Championships shall be comprised of a series of events.
3503 The Events in the series shall be decided by the Management Committee before the first event.
3504 Along with registering a boat entry for the championship season, a racing class along with two crew members shall be nominated. For that craft be eligible for championship points for any event throughout the year, one of the two nominated competitors shall be the driver.
3506 A competitor who has been disqualified from an event at any time throughout the years is ineligible for the Club Championship.
3507 To be eligible for the Club Championship a competitor shall officiate in one event of the series, serve on the Club Committee or perform some other service to the Club to the satisfaction of the Management Committee.
3508 The Club shall award the following perpetual trophies:
a) Club Champion – Outright
b) Champion - 2 Cylinder 2T, 3 Cylinder 4T (up to 1051cc) and Electric Combined
c) Champion - 3 Cylinder 2T and 4 Cylinder 4T up to maximum stated HP

3400 POINTS

Points for each event of the championship shall be allocated as follows

1st	100
2nd	80
3rd	70
4th	60
5th	50
6th	45
7th	40
8th	35
9th	30
10th	25
11th	20
12th	15
13th	10
14th	5

Starting but not finishing 1 point (for non-place getters)

Finishing, in addition to starting, but outside 13th place 5 points

3401 Points for the Avon Descent shall be doubled.

3402 Points shall be awarded regardless of the number of entries provided there is enough to make a class.

3403 Points are not transferrable or interchangeable between the Championships.

3404 The Rear Commodore shall keep a register of points gained and shall ensure that this register is available at all occasions where points are allotted.

3500 EVENT TROPHIES

Trophies or plaques shall be awarded for individual events of the championships.

3600 COMMODORES TROPHY

The perpetual Commodores Trophy shall be awarded to the Member who is nominated by any financial member of the Club and selected by the Commodore to have contributed most to furthering the aims of the Club.

3700 SWIMMING TEST REQUIREMENTS

A competitor must complete the swimming test under the following conditions:

- a 150 Meter swim test within ten (10) minutes
- a helmet and footwear shall be worn
- a lifejacket (PFD) shall not be worn
- a wetsuit shall be worn.

3701 PERIOD OF VALIDITY

The swimming test shall be valid until the expiry of a competitor's competition license.

3702 SUPERVISION

A swimming test shall only be conducted in conjunction with pre-event scrutineering for events of the State Championships or other time and venue approved by the Management Committee. Swimming tests shall not be held in a swimming pool.

3703 OTHER CERTIFICATES NOT RECOGNISED

Certificates from other clubs, societies or associations will not be considered as exemptions from the swimming test.

3800 COMPETITION LICENCES

ELIGIBILITY

A person applying for a Club Competition Licence shall:

- Be a financial member
- Be not less than ten (10) years of age.

3801 REQUIREMENTS

An applicant for a Club Competition Licence shall fulfil the following requirements:

- pass the Club swimming test upon joining the Club and must swim annually after having attained the age of seventy (70) years
- pass the Club swimming test, if their Competition Licence has lapsed for a period of greater than five (5) years
- Pay the annual fee
- Compete in a craft that has paid the annual Insurance Premium
- One competitor per craft must hold a current Recreation Skippers Ticket (RST).

3802 PERIOD OF VALIDITY

The fee for the Club Competition Licence shall be determined by the Management Committee.

3803 LAPSE OF A CLUB COMPETITION LICENCE

The period of validity shall lapse if the annual fee and / or insurance premium is not paid within thirty (30) days of the date of expiry.

3804 CANCELLATION / SUSPENSION

A Club Competition Licence may be cancelled or suspended by the Management Committee for a serious breach of these rules or for conduct, not necessarily in an event, contrary to the good image and repute of the Club.

3805 RE EXAMINATION / RE-ISSUE

A Club Competition Licence holder shall complete the swim test at the expiry of the period of validity before the licence is re-issued.

3806 If a Club Competition Licence is cancelled, all the test requirements shall again be satisfied before it is reissued.

3900 GENERAL LICENCE

To obtain this grade of Club Competition Licence a competitor shall:

- a) Be not less than seventeen (14) years of age as at the date of issue and have paid Club membership
- b) Fulfil the requirements for issue of a DOT RST
- c) Have completed the requirements of these Rules.

3901 MiniJet Novice

To obtain this grade of Club Competition Licence a competitor shall:

- a) fulfil the requirements of 3900
- b) be 17 years of age as at the date of issue
- c) have completed less than five circuit (closed) events and no river race events.

3902 MiniJet Expert

To obtain this grade of MJWA Competition Licence a competitor shall:

- a) Complete the requirements of 3900 & 3901 and;
- b) Be of 17 years of age as at the date of issue and;
- c) Have completed in minimum five circuit (closed) events and successfully completed a river race
- d) Minijet Expert license issue / removal can be at the discretion of the Management Committee on a performance, tenure and safety review basis.

4000 INSURANCE

4001 Each Competitor in an event shall be covered by the Club Public Liability.

4002 Insurance premiums shall be paid on a per craft basis. The premium for each craft's Insurance is payable annually (01 January to 31 December).

- 4003 The Insurance premium for each craft is payable annually regardless of the period for which the fee is paid. The Insurance Fee must be paid prior to any craft being permitted to race in any given season.
- 4004 In the event of any competitors lodging an Insurance claim, that particular craft will incur an additional Insurance premium if the members of the craft are not the original members of the craft.
- 4005 The Club Insurance Policy shall not be substituted by other Insurance Policies regardless of their provisions.
- 4006 The premium shall be paid before a Competition Licence is issued or re-issued.

4100 AMENDMENT OF COMPETITION RULES

- 4101 Any amendment, deletion, addition or change of meaning to any part of these Rules must be ratified by resolution of a majority of the financial members present at a general meeting.
- 4102 Members must be notified in writing of any proposed amendments, deletion, addition or change of meaning to any part of these Rules at least seven (7) days prior to the general meeting.
- 4103 Any Competition Rule or Specification that has been amended, deleted, added or changed in meaning by means shall not be amended, deleted added or changed in meaning again until at least twelve months after the first amendments, deletions, addition or changes in meaning, unless safety or regulatory impositions apply.
- 2430 For the purposes of 4103, notification in the MJWA Newsletter/Email of any proposed amendment, deletion, addition or change of meaning to any part of these rules shall be sufficient but not obligatory providing such notification occurs seven (7) days before the general meeting

End of Section.

VESSEL SPECIFICATIONS

5000 Registration

Each craft in an event shall be registered with the government department responsible for licensing marine vessels and comply with their requirements as follows:

- The registration number shall be displayed on each external side of the hull adjacent to the transom
- Each digit of the registration number shall be black and shall not be less than 150mm in height and not less than 25mm in width
- Each digit of the registration number shall be vertical and shall have a 10mm white surround
- Registration sticker fixed to the port (left) side next to the registration number
- The identification plate (HIN plate) shall be affixed to the hull as per DOT regulations.

5100 Identification Numbers NOVICE Class

Each craft shall display an identification number that shall:

- Be not less than 400 x 210mm for the background
- Be non-slanting and naturally spaced
- Be formed in Helvetica Condensed Bold font or other Management Committee approved similar font
- Be made from Neon Yellow Fuji Ca 12 long term adhesive vinyl 50 micron or Management Committee approved equivalent
- Be on a Black background of Fuji Ca 12 long term adhesive vinyl or Management Committee approved equivalent
- Not be displayed on a board on the craft
 - Be clearly visible on both sides of the craft with the entire number on a surface of the craft forward of amidships.
- No wrap around numbers allowed.



5200 Identification Numbers EXPERT Class

1216 Each craft shall display an identification number that shall:

- Be not less than 400 x 210mm for the background
- Be non-slanting and naturally spaced
- Be formed in Helvetica Condensed Bold font or other Management Committee approved similar font
- Be made from Bright RED (#DE1738) Fuji Ca 12 long term adhesive vinyl 50 micron or Management Committee approved equivalent
- Be on a White background of Fuji Ca 12 long term adhesive vinyl or Management Committee approved equivalent
- Not be displayed on a board on the craft
 - Be clearly visible on both sides of the craft with the entire number on a surface of the craft forward of amidships.
- No wrap around numbers allowed.



5300 DIMENSIONS

The minimum hull length shall be 2300mm and the maximum hull length shall not exceed 4000mm.

5400 DESIGN and SAFETY

- The design shall be of a safe design and construction. The hull shall contain an engine cover (hatch) and a bulkhead to separate the occupants from the engine compartment.
- Hull and propulsion supporting structure shall be made from aluminium.
- Buoyancy must be added to a boat with a minimum available air volume of 0.2M² or 200L effective capacity.
- Must be able to house two occupants.
- UHMWPE under-sheet for protection of hull shall be fitted for all river events. Coverage shall be not less than the keel of the hull at a width equal to the minimum of the delta at the widest point. Trimming of the UHMW is permissible to follow the hull shape to the point. **See Reference Drawing No. 1 & 1A**
- Paint and unpainted hulls are permitted - colour is free
- Craft shall have a minimum of 1 dead man safety ignition cut
- A fire extinguisher of not less than 1KG is to be fitted in a safe and accessible location
- Batteries must be of a fully sealed type and must be secured to the hull or bulkhead in a design fit to support the battery weight in the event of an accident or roll over
- Fuel tank is to be made from any metal. (aluminium/stainless steel etc)
- Fuel tank capacity is limited to maximum of 80L. Fuel tanks must vent externally of the engine room and contain a one way valve to prevent fuel escape in the event of submergence.
- Fuel filling points must be of OEM type or those found acceptable for marine use. Fillers must have an O ring seal and be non-venting type. It is recommended to have the fill point external of the engine room. Craft that have an internal fill point must have an operational bilge blower fitted.
- A minimum of two 300mm grab rails shall be fitted to the hull to allow for recovery and manoeuvring while on water. Grab rails to be fitted between the tip of the bow and the base of the windscreen. Additional grab rails can be fitted. The location of additional grab rails is free.
- Each craft shall carry a minimum first aid kit including items from St John Medium Leisure Kit Part number 7652. Alternative safety kits can be used save that the contents is the same.
- Each craft shall have a tow rope. The tow rope must be not less than 10M in length and rated to not less than one tonne at 10 metres.
- Each craft shall carry a throw rope safety bag for river racing events.
- Exhaust outlet point must be rearward of the bulkhead by no less than 500mm and as low in the hull as practicably possible.. The exhaust exit must face in a direction opposite to that of the normal direction of movement.
- Bilge pump/pumps must be fitted to the engine compartment and have capacity of not less than 900 GPH combined. Pumps must be fitted with a non-return valve if the discharge point is below the floating stationary water line at race weight.
- Bilge pumps must have a fully automatic operation by way of internal float, automatic time sensing or external float switch and must remain operable in the event that the motor is not running. Pumps can run continuously if switched on with main isolation switch and are designed to do so.
- It is recommended that a second bilge pump of not less than 500GPH be fitted in the occupant's compartment forward of the bulkhead and in the lowest point of the hull. If the bulkhead is fully seal welded to the hull and side plates a bilge pump **MUST** be fitted to the forward compartment.
- The use of the OEM bilge venturi system is acceptable only as addition to bilge performance. The OEM system alone is not permissible but if used as additional must be fitted with an inline check valve.

5500 TOW POINT

- A Tow Point must be fitted no more than 150mm to the rear of the furthest forward point of the bow. The tow point

shall be of a solid structure not less than 8mm in thickness. It shall be shaped in a closed half circle with not less than 20mm and not more than 50mm internal diameter. It shall be capable of supporting the craft under tow when it is fully immersed in water.

- A single rear tow point shall be fitted to the craft to be used for recovery or tow of other craft. Craft fitted with rear bar work surrounding the pump shall be deemed as having a suitable tow structure.

5600 SAME CRAFT TO BE USED

The same craft with the exception of allowable replacement parts shall be used throughout an event.

5700 ADDITIONAL EQUIPMENT

Mini Jet Boats are shall comply with Specification 5000 – 5500 and 5800 - 5900 inclusive.

5800 PROPULSION SYSTEMS

- Jet drive units only
- Fabricated, cast or OEM inlet tunnels are permitted
- The use of aftermarket jet impellers is permitted
- The maximum internal diameter of any housing including wear ring is 161mm
- Steering nozzles are free
- Intake screens are free
- Ride plates are free
- Trim of the steering nozzle is free
- The shortening of the drive coupler intermediate shaft is permitted
- Rubber drive couplers and flanges are free
- A maximum of 12 veins may be used in the impeller duct assembly
- It is permitted to block the tell-tale or venturi outlet

5900 ENGINES

- Any two or four stroke marinised power plant is acceptable.
- Electric motor driven jet units are permitted.
Rated HP is to be no more than 180HP for Circuit events and 170HP for river events.
- Removal of automatic oil injection systems is permitted.
- The power plant shall have a manufacturer placard stating HP
- Exhaust systems are free in design, shape and size
- A wet exhaust muffler system (waterbox) with minimum of one baffle shall be installed. No dry piped or side exit exhausts are permitted.

6000 MiniJet CLASSES

- Minijet class will utilize GPS recorded speed data for maximum speeds for river events. System to be approved DART model. A nominated timekeeper will be responsible for the data capture and presentation of speeding events to the race director for results preparation within 15 to 30 minutes of the race finish for all craft.
- Results of timing are as per rule 1600 of this document.
- Minijet Novice have a max 50kph for river racing events and max 60kph for circuit racing events regardless of HP.
- Minijet Expert have a max 60kph for river racing events and max 70kph for circuit racing events regardless of HP.

6100 Avon Descent Specific Requirements

The following additional Specifications apply to compete in the Avon Descent.

6101 – Safety Structure

- A safety hoop structure shall be fitted behind the occupants on the same plane as the fire wall section. Safety hoop / hoops shall be of aluminium, construction, 38mm outer diameter and a wall thickness of not less than 3mm. The internal bend radius shall not be less than 100mm.
- The hoop/hoops shall finish at a horizontal height above the gunwale that provides support to the rear of the helmet of the occupant and is in line centrally with the occupant seating position. **See Reference Drawing No. 2**
- The hoop/hoops shall be cold formed and attached to the firewall/gunwale by way of keeper plate above and below the attaching panel or fully welded. If bolted a minimum of six bolts of Grade 8.8 and washers shall be used and the keeper plate shall be of minimum 6mm thickness and fully welded to the hoop structure.

6102 – Neck Support

- Occupants are required to wear an SFI 3.3 approved full neck collar along with all safety and clothing requirements outlined within these Rules.

6103 – Speeds & Penalty

- Excess of speed events totalling 5 Minutes will result in an ROF grid for the following day
- Excess of speed events totalling 10 Minutes will result in an event suspension of 1yr
- Excess of 70Km/hr at any time shall result in a life ban from the event
- Novice Speed nominated at 50Km/hr – Penalties are incurred from 51Km/hr
- Expert Speed nominated at 55Km/hr – Penalties are incurred from 56 Km/hr

End of Section.

Reference drawings Below

Reference Drawing 1 – Rear Typical view showing wear plate on delta in **RED**

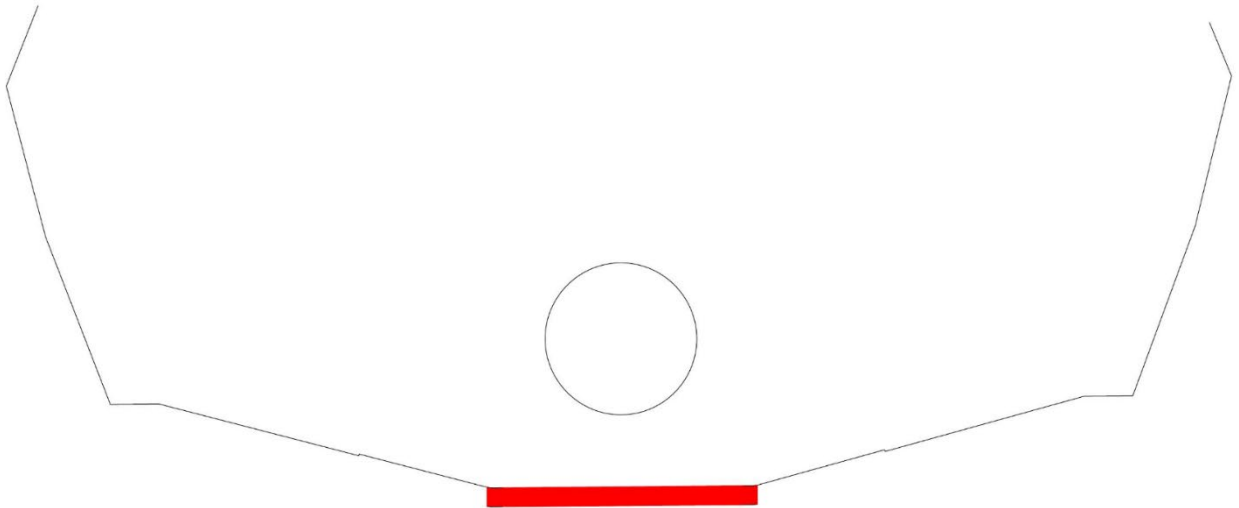

Reference Drawing 1A – Underside of typical hull. **Blue** line showing minimum wear plate coverage

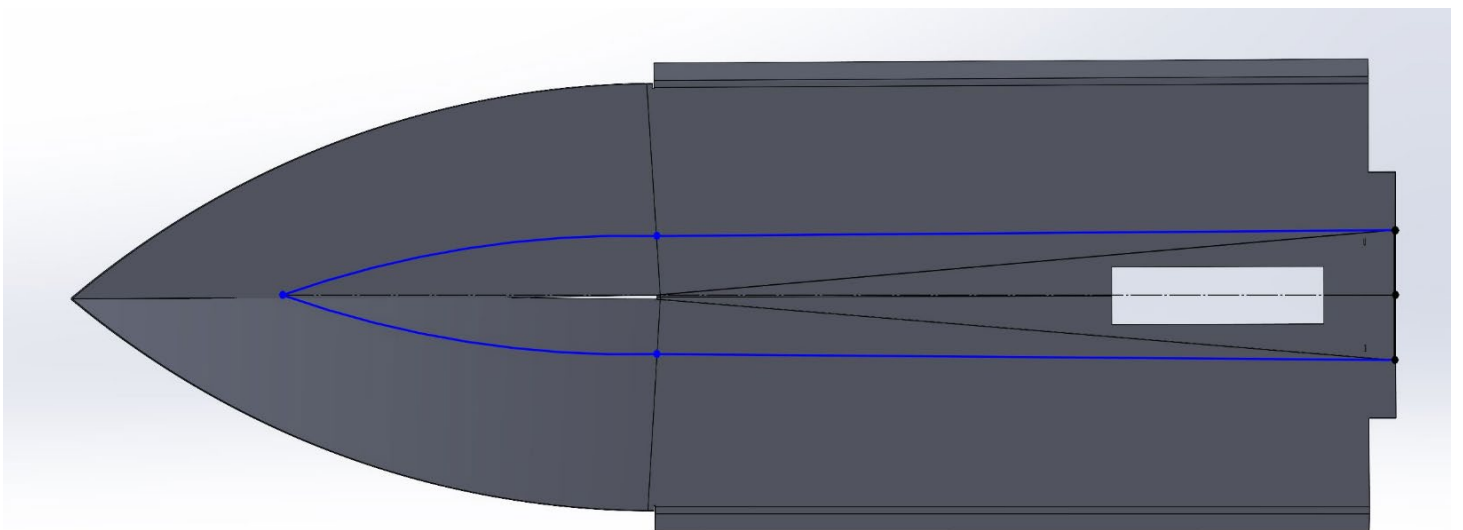

Reference Image of typical wear plate installation minimum

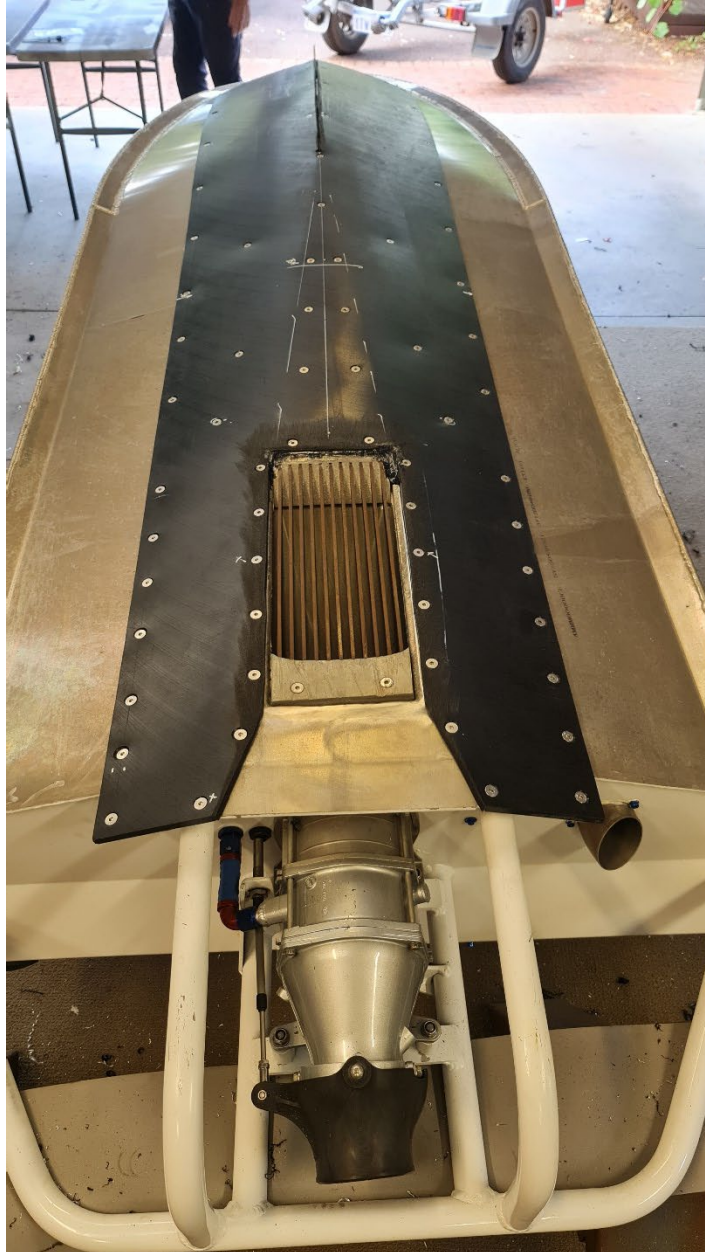

Reference Drawing 2 – Side sketch of typical craft showing **BLUE** head protection loop fitted. Note top of loop is as close to centre of helmet for occupant as possible.

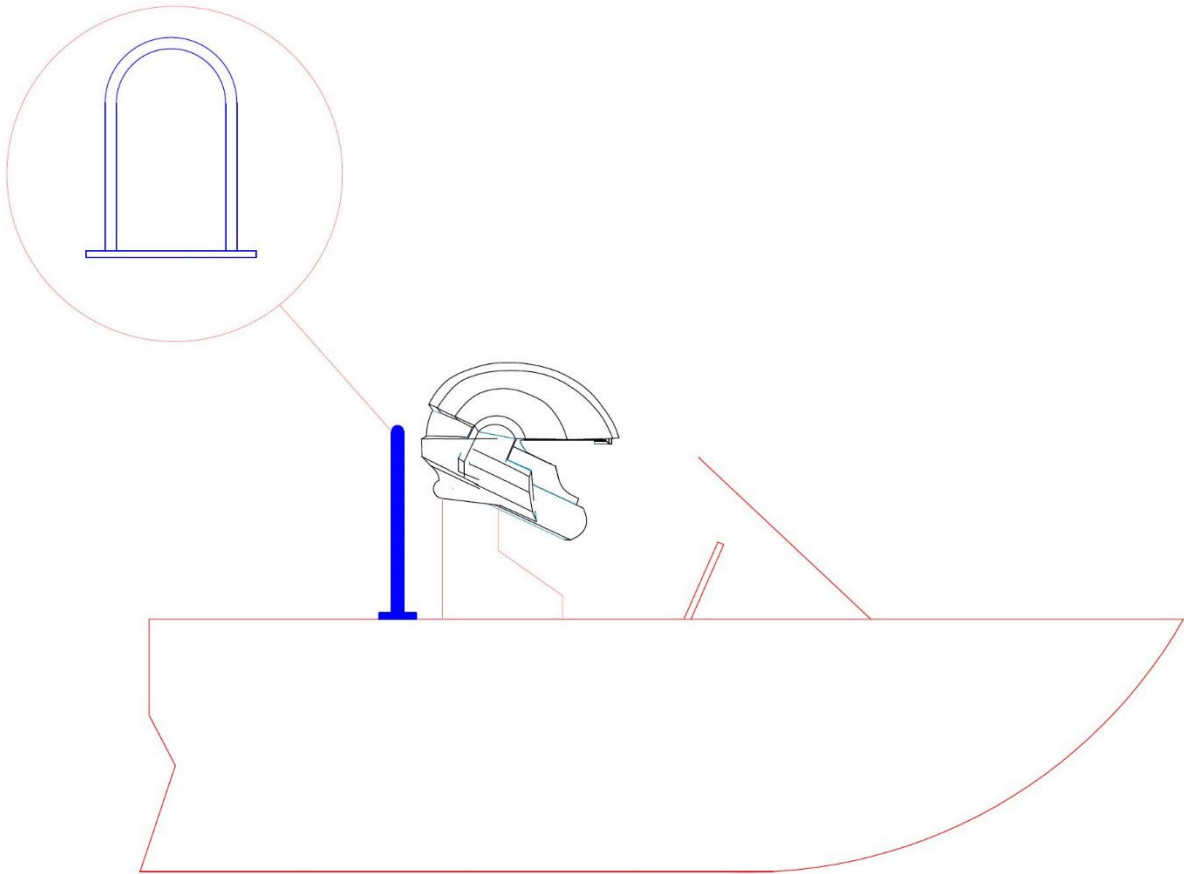

End of Document.